

# DISPLAY | Espositori da banco

ESPOSITORI REFRIGERATI DA BANCO

## RG 800



GAS  
R290

M1  
-1°C  
+5°C

E  
ENERGY  
CLASS

3  
+25°C/60RH



### DETTAGLI



Termostato Digitale



Ripiani regolabili in vetro



Luce LED interna



## CARATTERISTICHE GENERALI

- Espositore orizzontale refrigerato da banco
- Vetro quadrato con cornice nero e basamento in acciaio inox
- Refrigerazione Ventilata
- Evaporatore con copertura anti-corrosione
- Sbrinamento automatico a fermata compressore
- Controllo con display digitale
- Luce interna LED
- Doppio vetro temperato di sicurezza con Low-e (Vetri a bassa emissività)
- Porte scorrevoli posteriori
- Ripiani regolabili in vetro (N.2 Pcs)
- N.4 Piedini regolabili
- Classe energetica: E

## SPECIFICHE TECNICHE

|                                  |                |
|----------------------------------|----------------|
| Capacità                         | 180 L          |
| Temperatura                      | M1 (-1°C-+5°C) |
| Consumo                          | 6.83 kWh/24h   |
| Potenza Nominale                 | 450 W          |
| Rumorosità                       | 50 dB(A)       |
| Peso Netto                       | 105 Kg         |
| Peso Lordo                       | 125 Kg         |
| Dimensioni Esterne (LxPxH mm)    | 792x676x731    |
| Dimensioni Interne (LxPxH mm)    | 749x613x409    |
| Dimensioni Imballo (LxPxH mm)    | 860x750x850    |
| Quantità di carico 20'/40'/40'HQ | 36/82/123      |

## CERTIFICAZIONI

CE RoHS

## INGOMBRO PRODOTTO

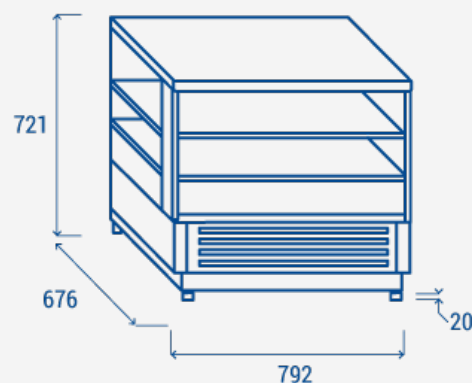

**COOL HEAD EUROPE**  
We make the world a cooler place

www.coolheadeurope.com